

# Analysis of Down-Conversion Filters

Fatih Porikli, January 2004

# Basic DCT Formulation

DCT analysis and synthesis equations:

$$X[k] = \alpha \sum_{n=0}^{N-1} x[n] \cos\left(\frac{2n+1}{2N}\pi k\right)$$

$$x[n] = \beta \sum_{k=0}^{N-1} X[k] \cos\left(\frac{2n+1}{2N}\pi k\right)$$

Where  $\alpha, \beta$  are constants depending the size of the DCT window.

# Pseudo-Reference Method

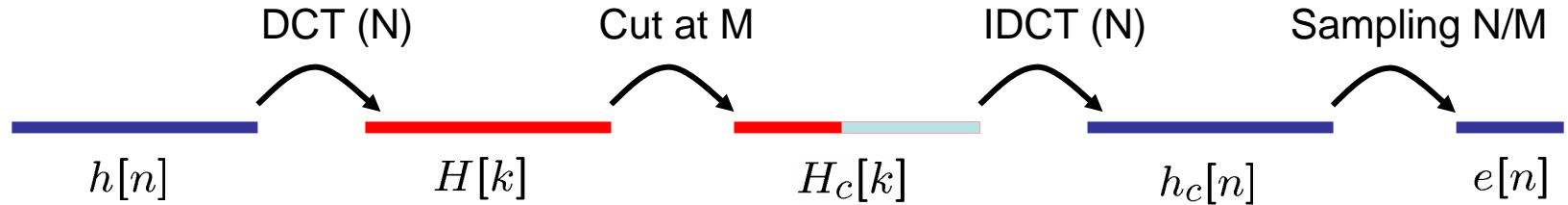

$$H[k] = \alpha \sum_{n=0}^{N-1} h[n] \cos\left(\frac{2n+1}{2N}\pi k\right) \quad H_c[k] = \begin{cases} \alpha \sum_{n=0}^{N-1} h[n] \cos\left(\frac{2n+1}{2N}\pi k\right) & k = 0, \dots, M-1 \\ 0 & k = M, \dots, N-1 \end{cases}$$

$$\begin{aligned} h_c[n] &= \beta \sum_{k=0}^{N-1} H_c[k] \cos\left(\frac{2n+1}{2N}\pi k\right) \\ &= \beta \sum_{k=0}^{M-1} H[k] \cos\left(\frac{2n+1}{2N}\pi k\right) \\ &= \alpha\beta \sum_{k=0}^{M-1} \left[ \sum_{s=0}^{N-1} h[s] \cos\left(\frac{2s+1}{2N}\pi k\right) \right] \cos\left(\frac{2n+1}{2N}\pi k\right) \\ &= \alpha\beta \sum_{s=0}^{N-1} h[s] \sum_{k=0}^{M-1} \cos\left(\frac{2s+1}{2N}\pi k\right) \cos\left(\frac{2n+1}{2N}\pi k\right) \end{aligned}$$

$$e[n] = h_c\left[\frac{N}{M}n\right] = \alpha\beta \sum_{s=0}^{N-1} h[s] \sum_{k=0}^{M-1} \cos\left(\frac{2s+1}{2N}\pi k\right) \cos\left(\frac{2\frac{N}{M}n+1}{2N}\pi k\right)$$

# Current Method

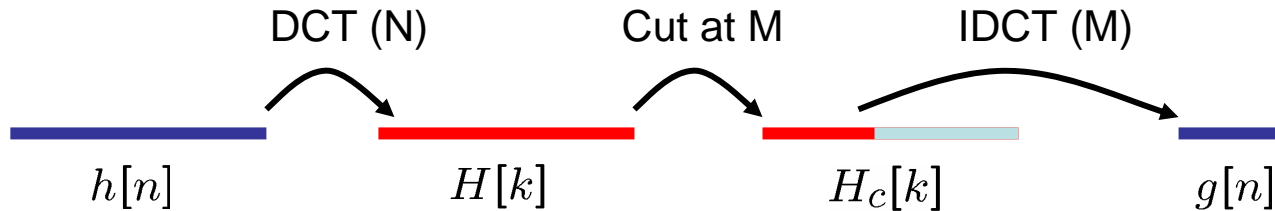

$$\begin{aligned}
 g[n] &= \beta \sum_{k=0}^{M-1} H[k] \cos\left(\frac{2n+1}{2M}\pi k\right) \\
 &= \alpha\beta \sum_{k=0}^{M-1} \left[ \sum_{s=0}^{N-1} \cos\left(\frac{2s+1}{2N}\pi k\right) \right] \cos\left(\frac{2n+1}{2M}\pi k\right) \\
 &= \alpha\beta \sum_{s=0}^{N-1} h[s] \sum_{k=0}^{M-1} \cos\left(\frac{2s+1}{2N}\pi k\right) \cos\left(\frac{2n+1}{2M}\pi k\right) \\
 e[n] &= \alpha\beta \sum_{s=0}^{N-1} h[s] \sum_{k=0}^{M-1} \cos\left(\frac{2s+1}{2N}\pi k\right) \cos\left(\frac{2\frac{N}{M}n+1}{2N}\pi k\right)
 \end{aligned}$$

# 1. Edge Offset

$$g[n] = \alpha\beta \sum_{s=0}^{N-1} h[s] \sum_{k=0}^{M-1} \cos\left(\frac{2s+1}{2N}\pi k\right) \cos\left(\frac{2n+1}{2M}\pi k\right) \quad \text{Current}$$

$$e[n] = \alpha\beta \sum_{s=0}^{N-1} h[s] \sum_{k=0}^{M-1} \cos\left(\frac{2s+1}{2N}\pi k\right) \cos\left(\frac{2\frac{N}{M}n+1}{2N}\pi k\right) \quad \text{Pseudo-Reference}$$

By rearranging terms in the second cosine, we find that

$$\cos\left(\frac{2\frac{N}{M}n+1}{2N}\pi k\right) = \cos\left(\frac{\left(2\frac{N}{M}n+1\right)(M/N)}{2N(M/N)}\pi k\right) = \cos\left(\frac{2n+\frac{M}{N}}{2M}\pi k\right) = \cos\left(\frac{2\left(n+\frac{M}{2N}-\frac{1}{2}\right)+1}{2M}\pi k\right)$$

Thus, we obtain

$$\begin{aligned} e[n] &= g\left[n + \frac{M}{2N} - \frac{1}{2}\right] \\ g[n] &= e\left[n - \frac{M}{2N} + \frac{1}{2}\right] \end{aligned}$$

In case **8:4** down-conversion, the offset is

$$\frac{M}{2N} - \frac{1}{2} = \frac{4}{2 \cdot 8} - \frac{1}{2} = \frac{1}{4}$$

In case **8:3** down-conversion, the offset is

$$\frac{M}{2N} - \frac{1}{2} = \frac{3}{2 \cdot 8} - \frac{1}{2} = \frac{5}{16}$$

## 2. Spacing Between Down-Sampled Pixels

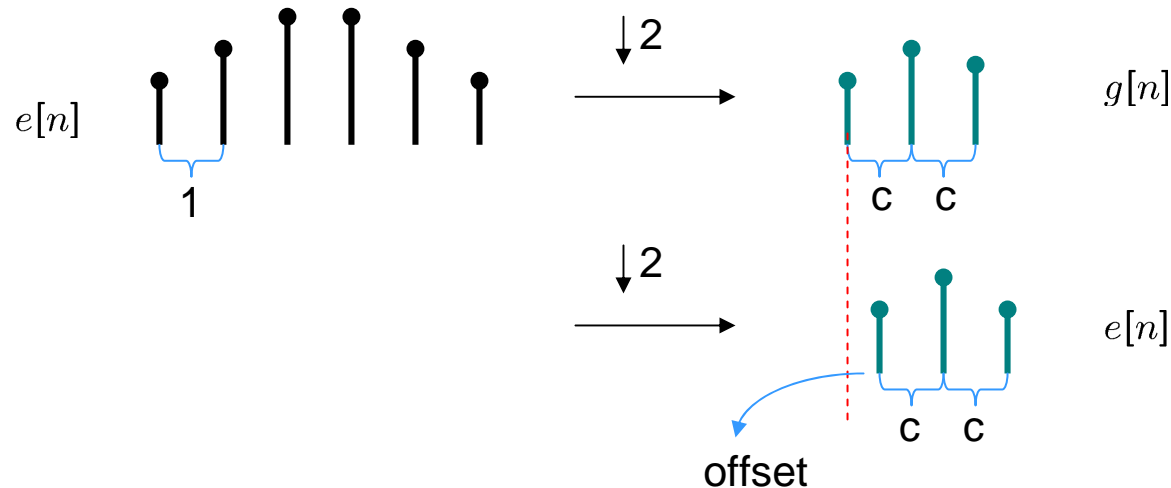

We find that the current filter  $g[n]$  has only a fixed spatial shift  $-M/2N + 1/2$  when we compare it with the pseudo-reference filter  $e[n]$

$$g[n] = e\left[n - \frac{M}{2N} + \frac{1}{2}\right]$$

This implies that the separation between the down-sampled pixels is constant. Otherwise, the spatial index term, i.e.  $n$ , should have been in the obtained spatial shift value.

Note that DCT of a real signal is also real, which means the transform has zero phase, since DCT only involves cosine decomposition as opposed to exponentials as in the DFT. This shows that there is no spacing change between the pixels.

# 3. Impulse and Frequency Responses

The conventional frequency response is defined for linear, shift-invariant systems (e.g. DFT)

$$x[n] * y[n] \longleftrightarrow X[k]Y[k] \quad \sigma[n] * h[n] \longleftrightarrow H[k]$$

Note that the current down-conversion filter set is applied as a matrix multiplication:

$$y = Ax$$

Where  $g$  is the down-converted signal,  $h$  is the input signal, and  $A$  is the filter set we computed. This transformation is linear, however it is not shift-invariant. Even if we decompose the transform space into sinusoidals, transformed function will not correspond to the conventional frequency response since the output is not the multiplication but the convolution of the transformed functions (by duality of DFT).

$$x[n] \cdot y[n] \longleftrightarrow X[k] * Y[k]$$

We can still obtain the frequency response for each component of the transformed signal using the filter bank representation of DCT:

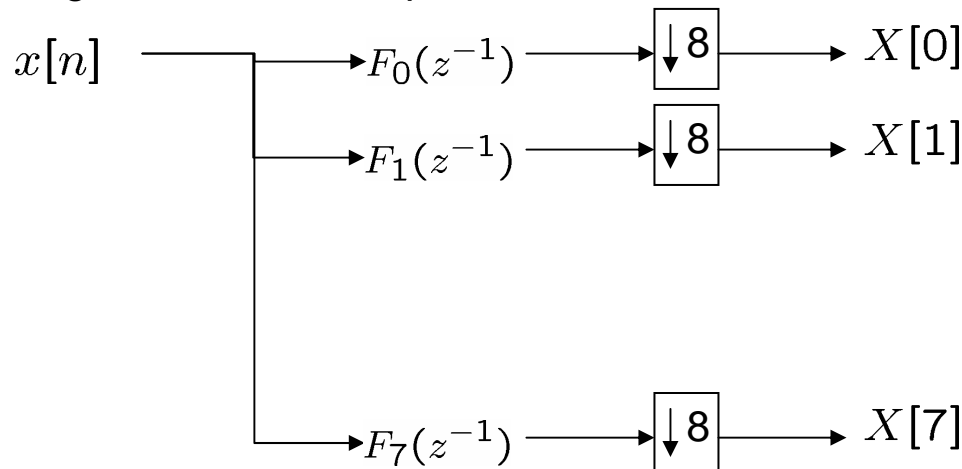

$$F_k(z^{-1}) = \sum_{n=0}^7 \cos\left(\frac{2n+1}{16}\pi k\right) e^{-jwn}$$

where

$$z = e^{jw}$$

# 3. Impulse and Frequency Responses

Using the previous filter bank representation, we can obtain the frequency responses of 8-point and 4-point DCT filters as

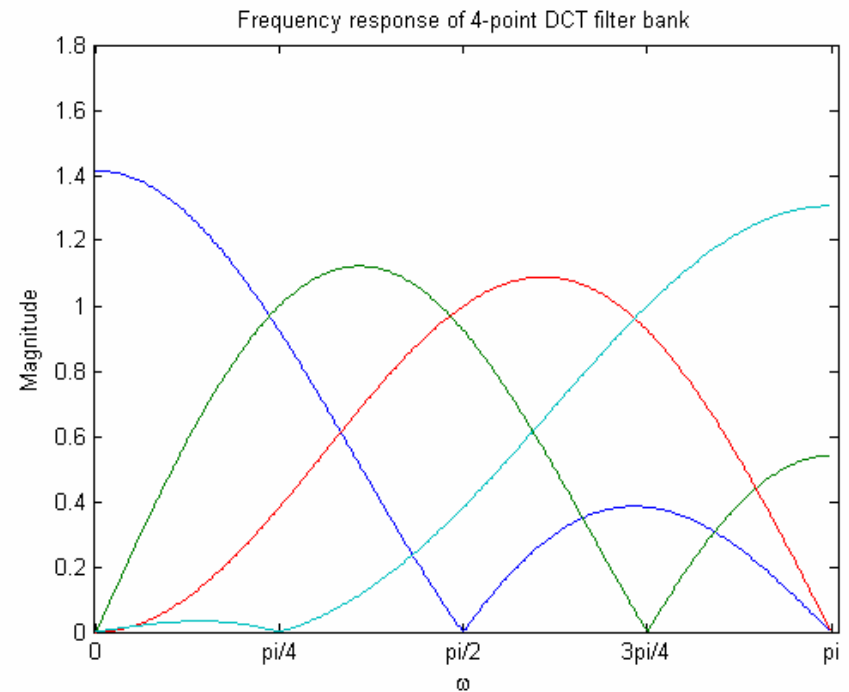
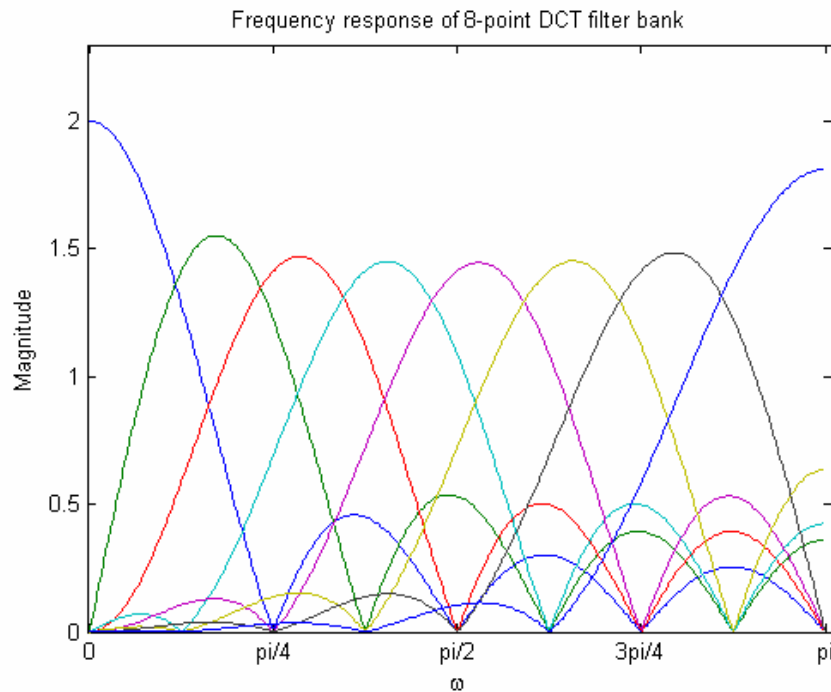

# 3. Impulse and Frequency Responses

Frequency responses of 3-point DCT filters then becomes

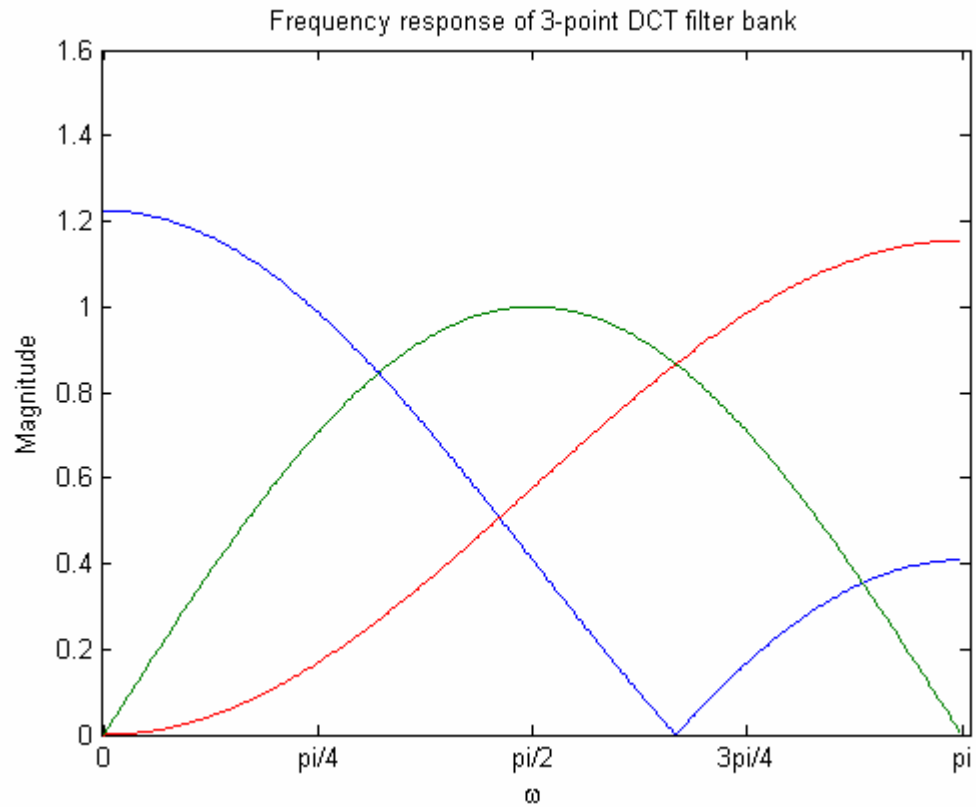

# 3. Impulse and Frequency Responses

We can understand filter characteristics by observing its response to impulses.

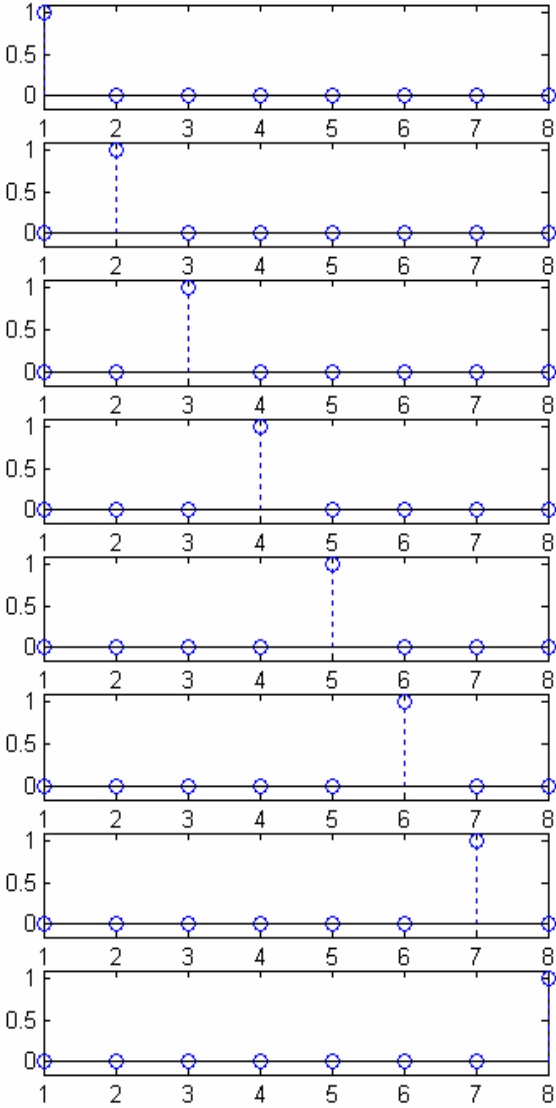

Original input signal

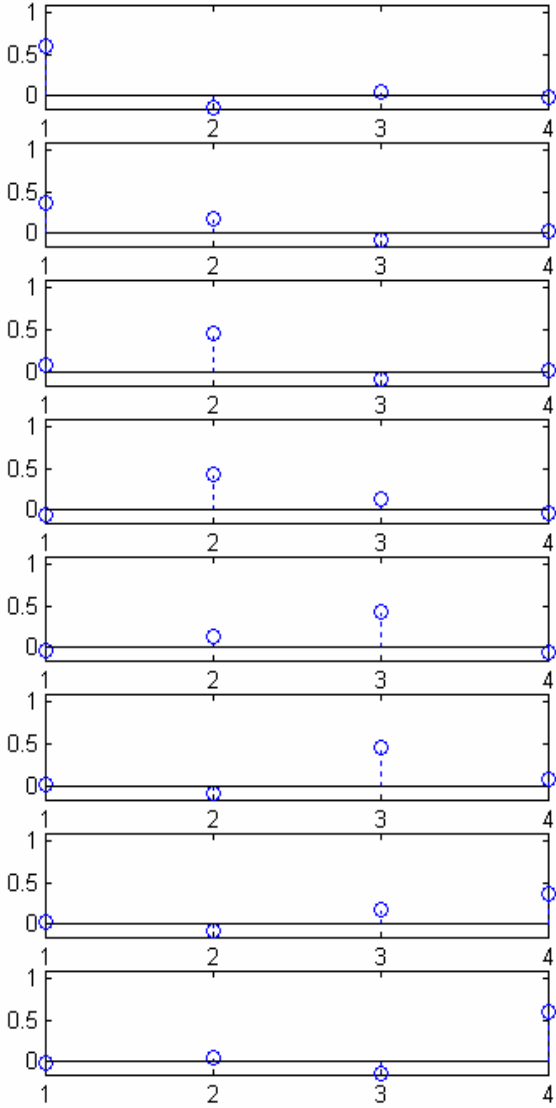

Down-converted by 8-to-4

# 3. Impulse and Frequency Responses

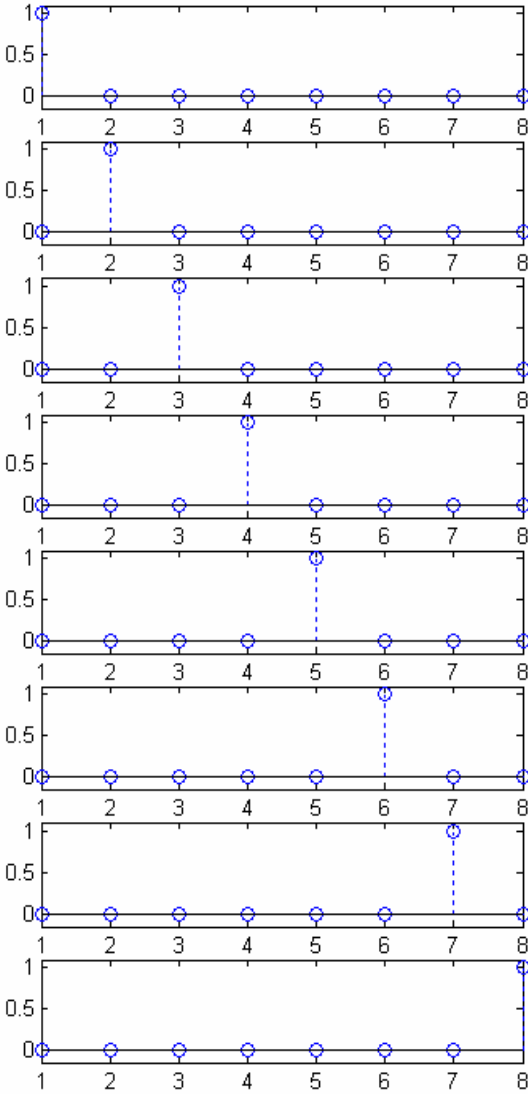

Original input signal

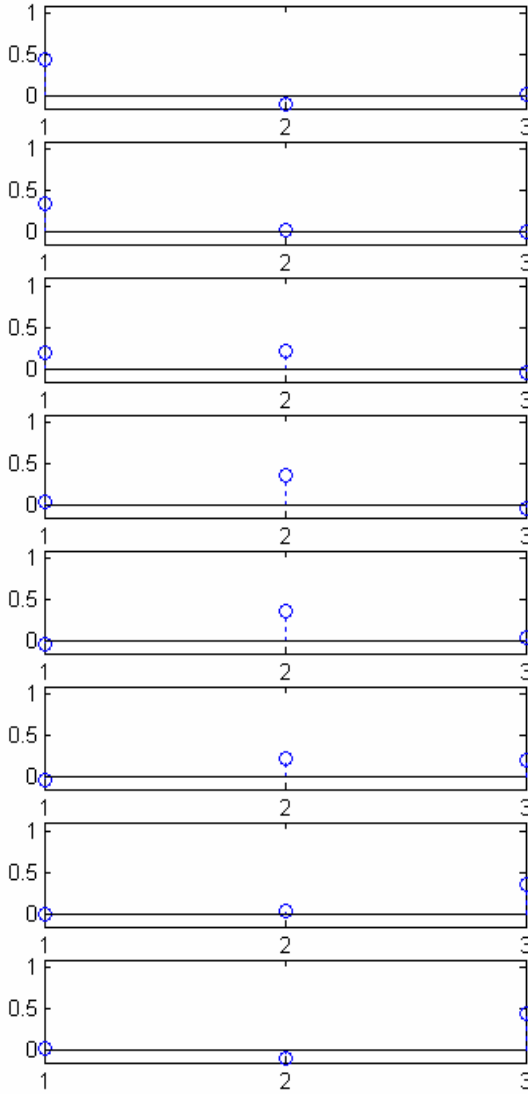

Down-converted by 8-to-3

# 3. Impulse and Frequency Responses

DCT of the 8-to-4 down-conversion filters. Each color corresponds to a separate filter.

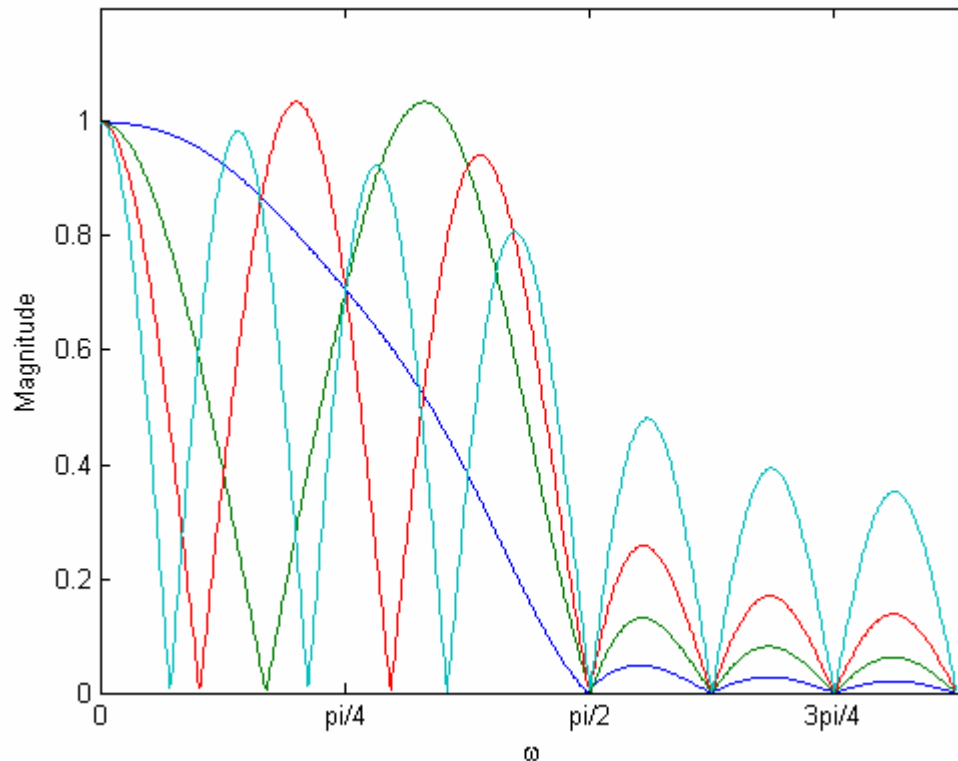

- n=1:  $[152 \ 94 \ 24 \ -12 \ -8 \ 6 \ 5 \ -5] / 256$
- n=2:  $[-35 \ 47 \ 121 \ 111 \ 36 \ -22 \ -17 \ 15] / 256$
- n=3:  $[15 \ -17 \ -22 \ 36 \ 111 \ 121 \ 47 \ -35] / 256$
- n=4:  $[-5 \ 5 \ 6 \ -8 \ -12 \ 24 \ 94 \ 152] / 256$

# 3. Impulse and Frequency Responses

DCT of the 8-to-3 down-conversion filters. Each color corresponds to a separate filter.

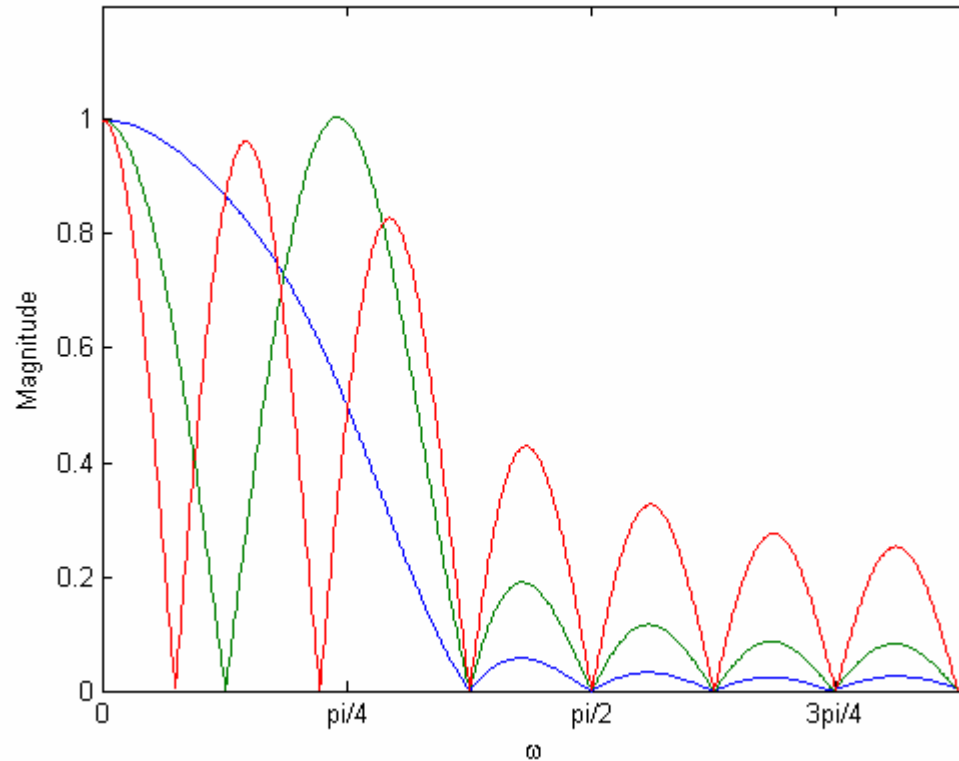

$$n=1: [116 \ 90 \ 51 \ 13 \ -8 \ -11 \ -2 \ 7] / 256$$

$$n=2: [-27 \ 8 \ 56 \ 91 \ 91 \ 56 \ 8 \ -27] / 256$$

$$n=3: [7 \ -2 \ -11 \ -8 \ 13 \ 51 \ 90 \ 116] / 256$$

# 3. Impulse and Frequency Responses

DFT of the 8-to-4 down-conversion filters. Note that filters have low-pass characteristics.

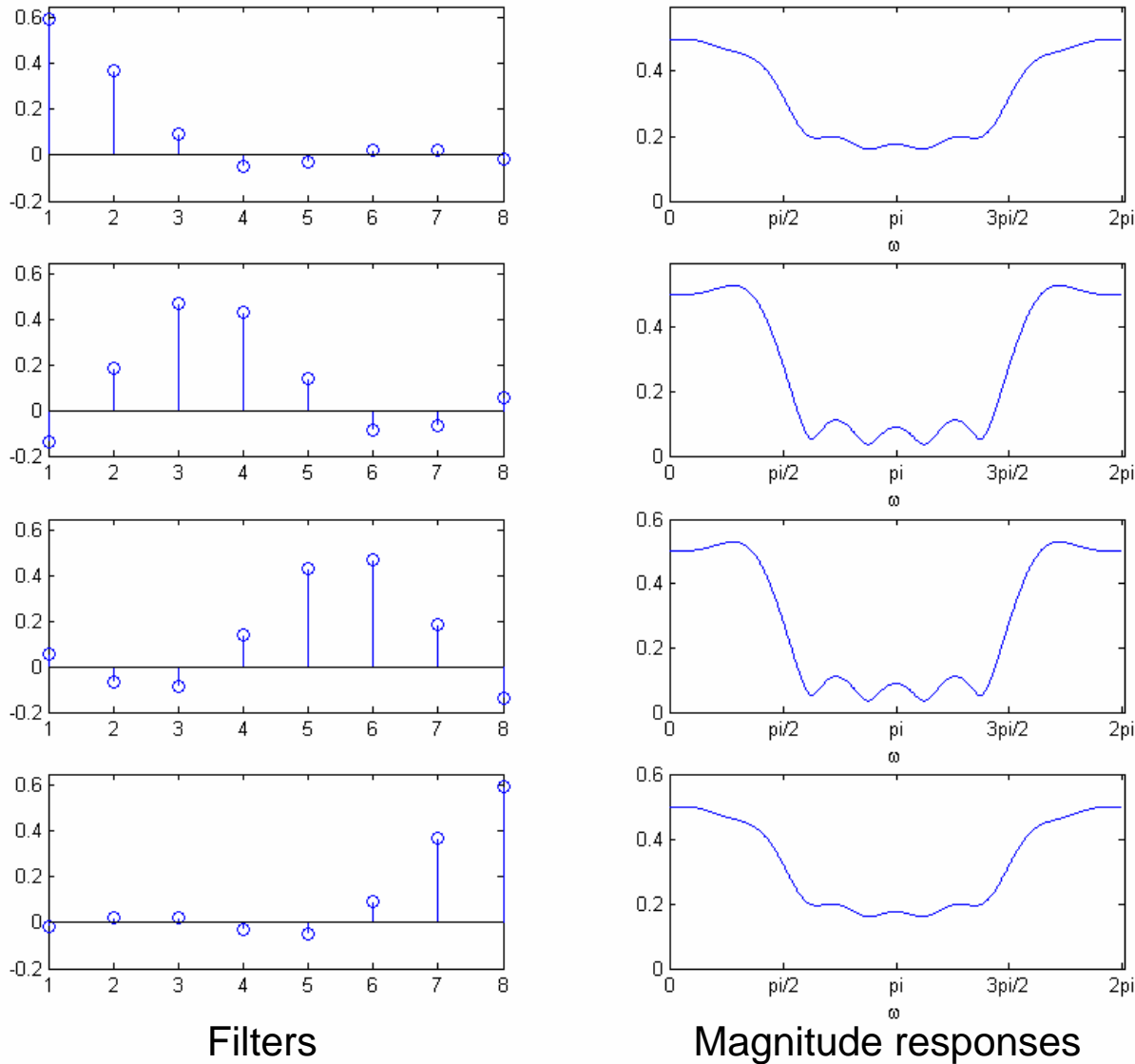

# 3. Impulse and Frequency Responses

DFT of the 8-to-3 down-conversion filters

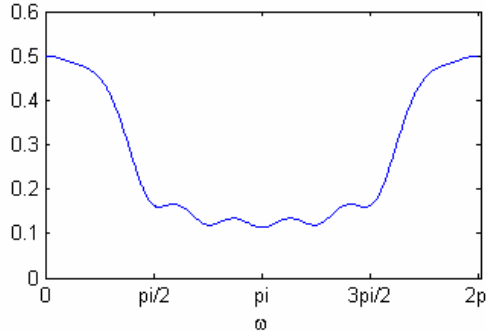
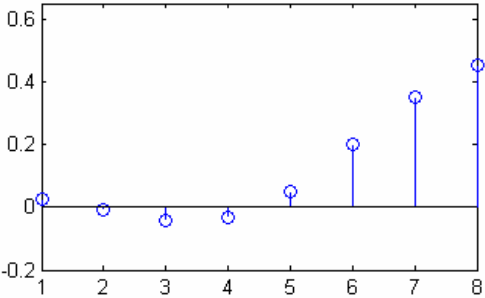
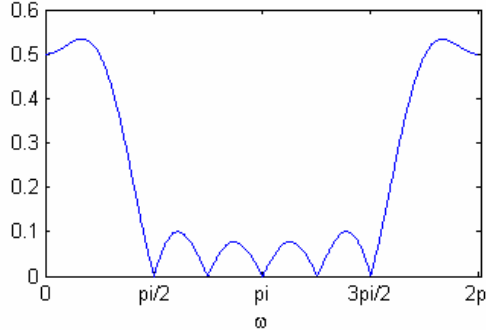
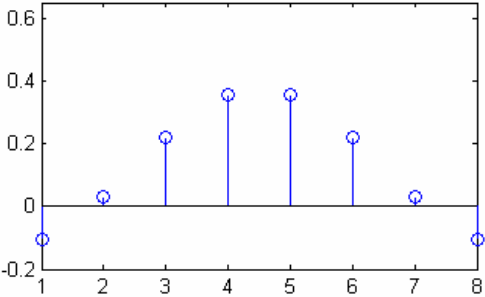
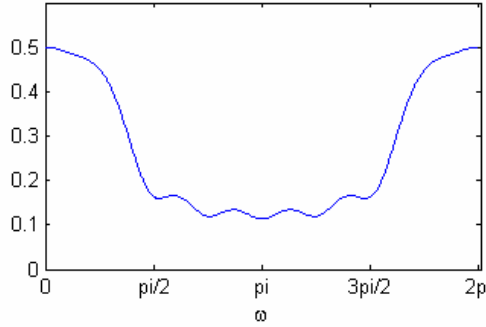
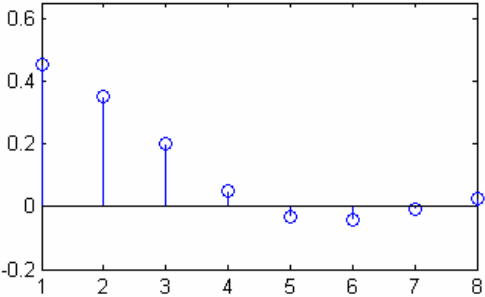

Filters

Magnitude responses